

## ADS1- Adhesive Delivery System

The ADS1 automatically replenishes adhesive to the desired level for your hot melt unit. A low level indicator sends a signal to the ADS1 that adhesive is needed, which then activates a venturi to draw the adhesive through a positive pressure air stream and deposit it into the hot melt unit.

### Energy Efficient

Low air consumption of only 20 SCFM at 50 psi during adhesive feeding.

### Flexibility

The ADS1 is compatible with most Nordson, Slatterback, ITW Dynatec, and Astro Packaging hot melt machine configurations.

### Reliability

Adhesive supply levels are automatically maintained with a sealed system that virtually eliminates system contamination.



### The ADS1 Features

- On-Demand adhesive replenishment saves operator time and prevents thermal shock to tank.
- Automatically feeds units up to 20 feet vertically and 100 feet horizontally.
- Adhesive wands can be used in various containers for efficient adhesive delivery.
- Alarm indicator lights alert fill/no fill status.
- Stainless steel construction for corrosion resistance.
- Transparent container allows for adhesive level visualization.

### Why choose Astro Packaging?

For over 25 years Astro Packaging has lead the industry with unmatched service, support, and manufacturing capabilities. Our factory trained technicians offer 24 hour technical support in both English and Espanol.

Visit us online at [www.astropackaging.com](http://www.astropackaging.com)

### ASTRO PACKAGING

3845 E. Miraloma Ave, Unit A  
800-642-7876 / 714-572-1094  
FAX 714-572-1943  
[www.ASTROPACKAGING.com](http://www.ASTROPACKAGING.com)



LIT - 10-501.5 - ADS1  
MADE WITH PRIDE IN THE U.S.A.



Quality You Can Trust  
Sales - Service - Support  
800-642-7876

# ADS1- Adhesive Delivery System

System:	ADS1
Adhesive Size:	Up to 1/2" Slat or Pellet
Adhesive Capacity:	55 gal (114kg or 250 lbs.)
Adhesive Transfer Rate:	340kg/hour (750lbs)
Adhesive Transfer Length:	Up to 6m (20ft) vertically and 30.5m (100ft) horizontally
Operating Air:	Minimum: 3.5 bar (.35Mpa or 50psi) Maximum: 5.5 bar (.55Mpa or 80 psi)
Air Consumption:	566 Liters/Min when feeding (20scfm)
Air Connection:	1" supply to 1/2" tube connection at unit

## Option Features

- Caster Base for mobility
- Capabilities for audible alarm or secondary stack light

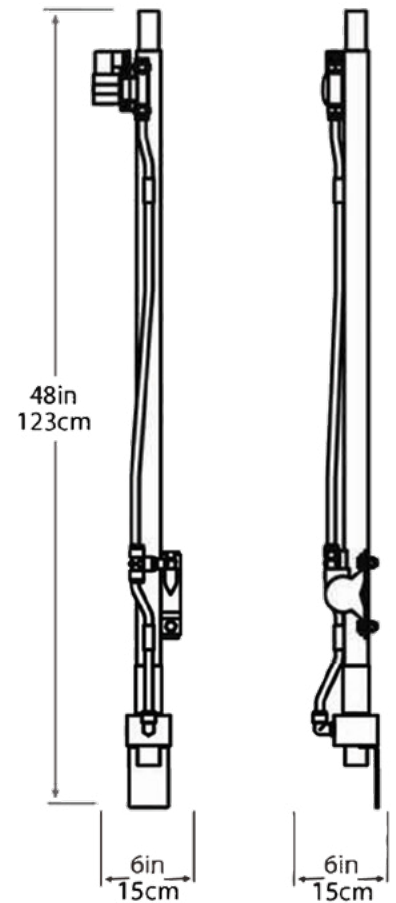
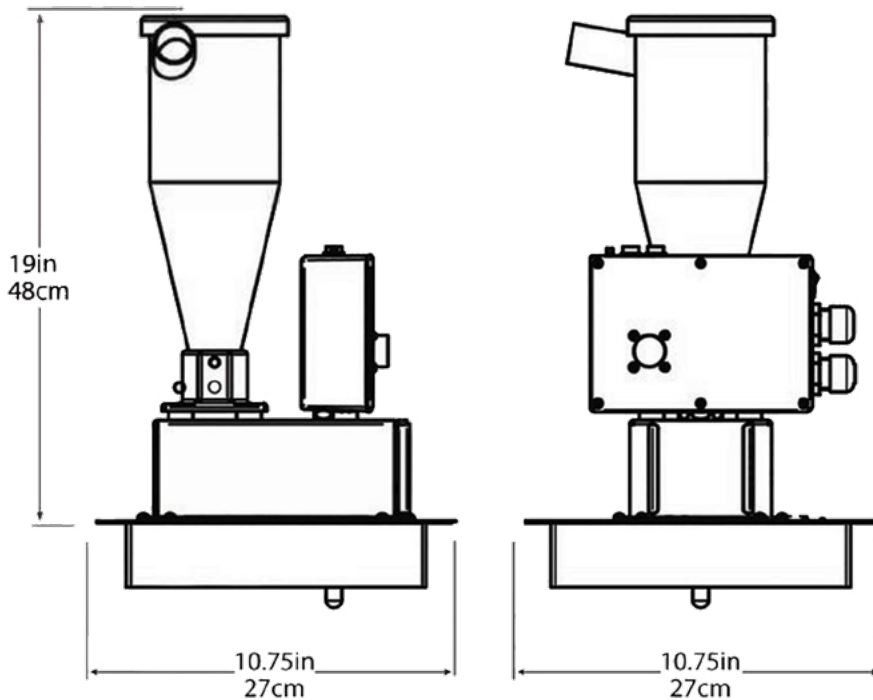

## ASTRO PACKAGING

3845 E. Miraloma Ave, Unit A  
800-642-7876 / 714-572-1094  
FAX 714-572-1943  
www.ASTROPACKAGING.com



LIT - 10-501.5 - ADS1  
MADE WITH PRIDE IN THE U.S.A.